

Product Range

Metal, plastic and ceramic pumps

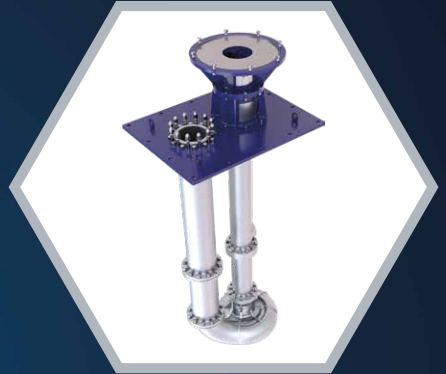

Customised Solutions

The optimal solution for your difficult conveying process.

Anyone looking for efficient, lasting and economical solutions to their demanding industrial conveyance applications needs more than just a coherent technical concept. Experience of the application, knowledge of materials and dialogue with our customer, are what ultimately leads to the optimal solution. This is the course which Rheinhütte Pumpen have followed for more than 160 years.

Rheinhütte Pumpen offers a broad selection of pumps in the most varied designs. With the extensive range of materials in metals, plastics, ceramics and designs which are adapted for particular media, our pumps are used for almost every challenging application.

We will develop individual pump designs for you. Always matched with your specific application and therefore providing you with flexible and economic solutions for your special conveyance requirement.

The most important applications of our pumps are:

- The chemical industry
- The petrochemical industry
- The oil and gas industry / refineries
- The mining and metallurgical industries
- The iron and steel industry
- Renewable energies
- Environmental management and recycling
- The consumer goods industry

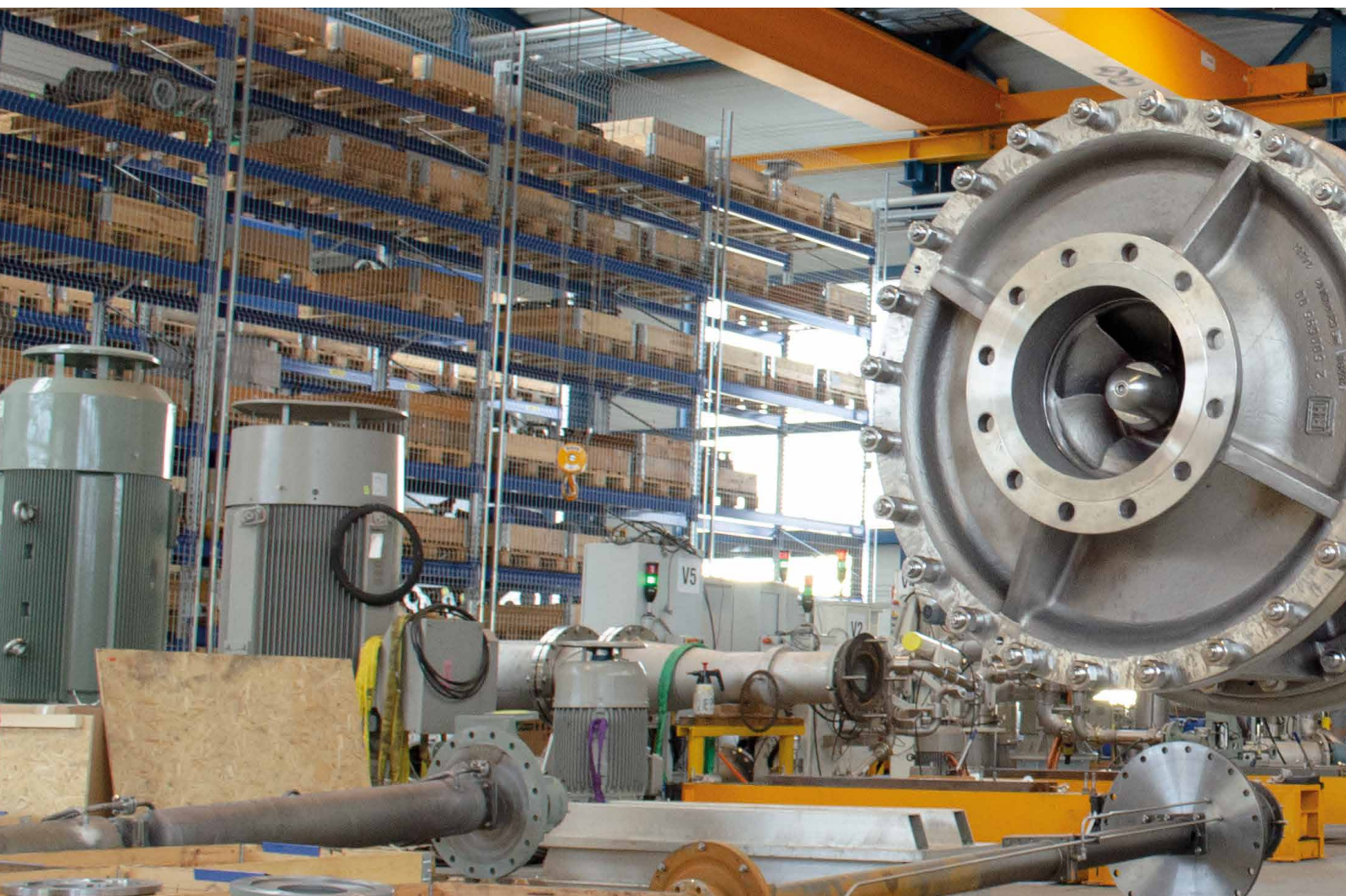

Processes and applications





in which we use customised designs:

- All stages of sulphuric acid production from molten sulphur to product acid and on to oleum and dilute sulphuric acid
- Manufacture of important chemical industry pre-products, for example phosphoric acid, nitric acid, sodium hydroxide and acetic acid
- All chlor-alkali electrolysis processes
- Flue gas scrubbing
- Steel and stainless steel
- Pickling processes
- Surface treatments such as painting processes and electroplating
- Conveyance of molten salts up to temperatures of 600 °C
- Conveyance of pitch and tar
- Fertiliser production, for example the conveyance of urea melt, phosphate ore digestion, nitric acid and ammonium nitrate.



Metal Pumps

Performance data and design features

				
Model Range	RN	RNSi	RMKN	RCE
Size DN	25 to 400	32 to 250	25 to 150	32 to 300
Q _{max} (m ³ /h)	2.700	1.500	500	1200
H _{max} (m)	150	100	150	180
Submersion depth _{max} (m)	–	–	–	–
T _{max} (°C)	+300	+300	+250	+450
Chemical standard	✓	✓	✓	–
Close coupled or flange motor design	–	–	RMKNF	–
Closed impeller	✓	✓	✓	✓
Open impeller	✓	–	–	✓
Propeller or helical impeller	–	–	–	–
Heatable	✓	✓	✓	✓
Back pull out design	✓	✓	✓	–
Stuffing box or shaft seal	–	–	–	✓
Mechanical seal	✓	✓	–	✓
Hydrodynamic seal	✓	✓	–	✓
Magnetic coupling	–	–	✓	–
Footstep bearing	–	–	–	–
Application	<ul style="list-style-type: none"> ▪ Ammonium sulphate ▪ Caustics soda ▪ Chemical industry ▪ NPK/fertilizer ▪ Sulphuric acid 	<ul style="list-style-type: none"> ▪ Sulphuric acid ▪ Titanium dioxide ▪ Pickling of steel and stainless steel 	<ul style="list-style-type: none"> ▪ Chemical industry ▪ Molten sulphur ▪ Nitric acid ▪ Sulphuric acid 	<ul style="list-style-type: none"> ▪ Ammonium nitrate ▪ Fertilizer ▪ Molten sulphur ▪ Phosphoric acid ▪ Slurry ▪ Sulphuric acid

Our range includes over 20 different metals. They differ from each other in terms of their alloying elements, their structure and their manufacturing process. As every alloy has its own characteristic properties, a suitable material can be used for each conveyance task:

- Heat resisting ferritic cast steel and wear resistant chrome-alloyed cast iron
- Highly corrosion-resistant chrome-

alloyed iron-silicon alloys with good wear resistance and excellent chemical resistance

- Semi and fully austenitic high alloy steel castings with good corrosion resistance: SIGUSS
- High alloy Rheinhütte special materials with medium-specific or process specific properties
- Pure metals such as titanium, Ti-Pd and nickel for the most demanding applications in certain critical media

					
RK	GVRN	GVSO	RCEV	RSU	RPROP
40 to 50	200 to 450	40 to 450	32 to 300	400 to 500	200 to 700
45	4000	4000	900	3400	8500
55	85	180	85	6	6,5
2	3,5	17,5	2	–	–
+100	+250	+600	+200	+150	+150
–	–	–	–	–	–
–	✓	✓	✓	–	RPROPF
–	✓	✓	✓	–	–
✓	–	–	✓	–	–
–	–	–	–	✓	✓
–	–	✓	✓	–	–
–	–	–	–	–	–
✓	✓	✓	✓	–	✓
–	✓	✓	–	–	✓
–	–	–	–	✓	–
–	–	–	–	–	–
✓	✓	✓	–	–	–
▪ Emergency pump	▪ Sulphuric acid	<ul style="list-style-type: none"> ▪ Chemical industry ▪ Chloralkali ▪ Molten salt ▪ Molten sulphur ▪ Oleum ▪ Sulphuric acid ▪ Solvents 	<ul style="list-style-type: none"> ▪ Dirty sulphur ▪ Fertilizer ▪ NPK/DAP ▪ Phosphoric acid ▪ Solids-containing fluids ▪ Sulphuric acid 	<ul style="list-style-type: none"> ▪ Sulphuric acid ▪ Titanium dioxide 	<ul style="list-style-type: none"> ▪ Fertilizer ▪ Crystal suspensions ▪ Brines ▪ Seawater ▪ Pulp mash ▪ Flue gas cleaning ▪ Titanium dioxide

Plastic Pumps

Performance data and design features

				
Model Range	CPDR	RCNku	RCNku+	RCKu
Size DN	32 to 80	80 to 400	32 to 150	25
Q _{max} (m ³ /h)	200	2.500	400	20
H _{max} (m)	100	100	110	50
Submersion depth _{max} (m)	–	–	–	–
T _{max} (°C)	+190	+190	+130	+130
Chemical standard	✓	✓	✓	–
Close coupled or flange motor design	CPDRB	–	–	RCKuF
Closed impeller	–	✓	✓	–
Open impeller	✓	–	–	✓
Vortex impeller	CPRF	RCKu	–	–
Back pull out design	✓	✓	✓	–
Mechanical seal	✓	✓	✓	✓
Magnetic coupling	–	–	–	–
Plastic lining	–	–	–	–
Armoured casing	✓	✓	✓	–
Foot bearing	–	–	–	–
Application	<ul style="list-style-type: none"> ▪ Brine ▪ Chloralkali ▪ Flue gas ▪ Hydrochloric acid ▪ Scrubber ▪ Sea water ▪ Steel industry ▪ Sulphuric acid ▪ Waste water 	<ul style="list-style-type: none"> ▪ Brine ▪ Chloralkali ▪ Flue gas ▪ Hydrochloric acid ▪ Scrubber ▪ Sea water ▪ Steel industry ▪ Sulphuric acid ▪ Waste water 	<ul style="list-style-type: none"> ▪ Brine ▪ Chloralkali ▪ Flue gas ▪ Hydrochloric acid ▪ Scrubber ▪ Sea water ▪ Steel industry ▪ Sulphuric acid ▪ Waste water 	<ul style="list-style-type: none"> ▪ Brine ▪ Chloralkali ▪ Flue gas ▪ Hydrochloric acid ▪ Scrubber ▪ Sea water ▪ Steel industry ▪ Sulphuric acid ▪ Waste water



FNP	FNPM	RVKu	RKuV
25 to 65	25 to 125	32 to 250	32 to 200
70	350	1.000	120
95	100	70	60
–	–	3	1,8
+190	+190	+90	+100
✓	✓	–	–
–	FNPMF	✓	✓
✓	✓	✓	–
–	–	–	✓
–	–	RVKuF	RKuVF
✓	✓	–	–
✓	–	–	–
–	✓	–	–
✓	✓	–	–
–	✓	–	–
–	–	✓	–

- Chemical industry
- Pharmaceutical industry
- Petrochemicals
- General processing technology

- Caustic soda
- Chloralkali
- Hydrochloric acid
- Organic Solvents
- Sulphuric acid
- Waste Water

- Chemical industry
- Fertilizer
- Sea water
- Sulphuric acid

- Chemical industry
- Hydrochloric acid
- Solids-containing fluids
- Sulphuric acid
- Sump pump



Plastics provide a good supplement to many areas of application. Our pumps are available in six different materials, each tailored to your specific application. Polyolefins and fluoropolymers used in solid designs: PP, PE 1000, PVDF, PFA, PTFE



Ceramic Pumps

Performance data and design features

Ceramic materials achieve universal corrosion and abrasion resistance during long operational lives. Rheinhütte Pumpen offers you a ceramic material optimised and proven for pump construction.

		
Model Range	FNC	FGP
Size DN	32 to 150	32 to 100
Q_{max} (m ³ /h)	600	700
H_{max} (m)	90	–
T_{max} (°C)	+120	+100
Chemical standard	✓	–
Closed impeller	✓	–
Open impeller	–	✓
Back pull out design	✓	–
Liquid ring pump	–	✓
Mechanical seal	✓	✓
Armoured casing	✓	✓
Application	<ul style="list-style-type: none"> • Chemical Industry • Solids-containing fluids • Titanium dioxide 	<ul style="list-style-type: none"> • Caustic gases • Chemical industry • Chlorine gas



Perfection Through Combination

Smooth conveying due to specific components



The safe conveyance of your media requires optimal coordination and combination of pump design, sealing system and pump material. We can supply all components needed to solve your particular conveyance requirements.

The right design for every task

Customer and market requirements are right from the initial developments of pump designs the focus of attention of Rheinhütte Pumpen. Our experience in pump selection makes us the specialist for the design of your application. We will select the right pump from our extensive range to match your conveyance need. More than 20 different types are available.

These designs can be attributed to the following pump ranges:

- Centrifugal pumps – horizontal and vertical
- Axial flow pumps
- Vortex pumps
- Standardised chemical pumps (ISO 2858, ISO 5199)
- Pumps for applications according to ISO 13709 (API 610)
- Liquid ring vacuum pumps



Mechanical seal

Single-acting, double-acting and stationary versions

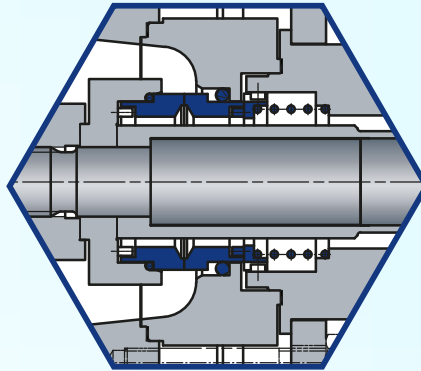

Stuffing box packing

In standard, heatable, refrigerable or gas-tight

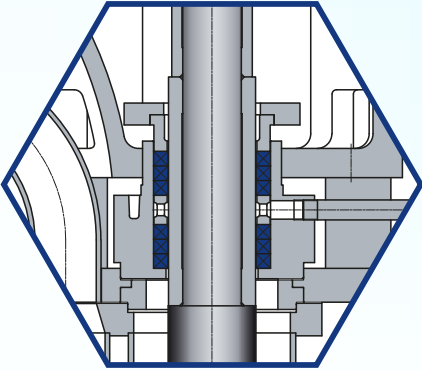

Lip ring seal

Sealed by dry-running or shaft seal rings

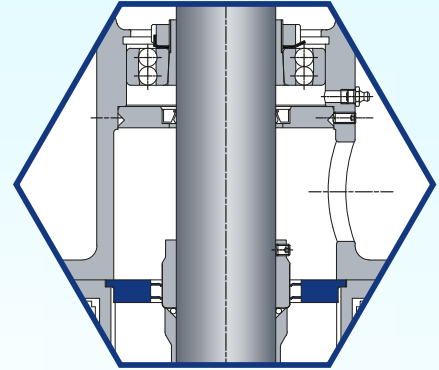

Sealing systems

for the optimal and safe solution

If the plant is to work safely and economically the pump design and sealing system must be perfectly matched with each other. A wide variety of seal variants is available when designing pumps.

The following sealing systems can be used depending on the conveyance conditions.

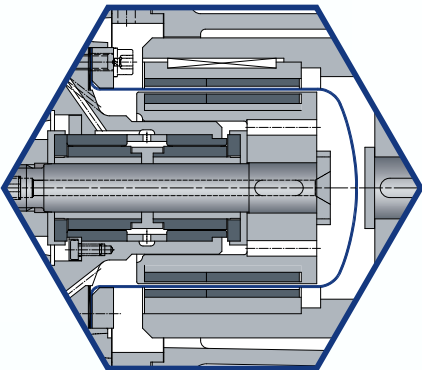

Magnetic coupling

Sealed by a spacer can in a range of materials

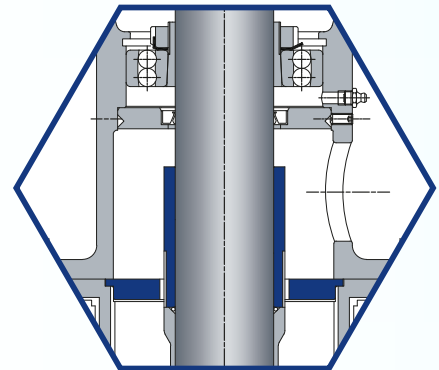

Labyrinth seal

Contact-free seal for non-pressurised container systems

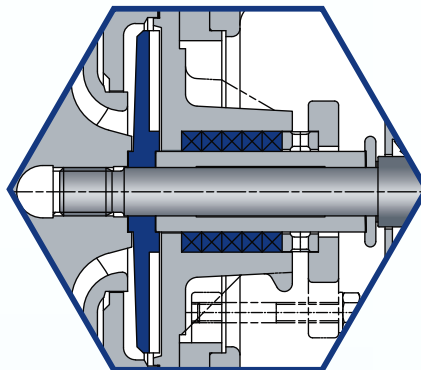

Hydrodynamic shaft seals

Using an impeller with back blades or one or more auxiliary impellers and a variety of stationary systems



— An ITT Company

ITT RHEINHÜTTE Pumpen GmbH
Rheingastrasse 96-98
D-65203 Wiesbaden
T +49 611 604-0
info@rheinhuette.com
www.rheinhuette.com