

Chloralkali Electrolysis

Horizontal and Vertical Pumps

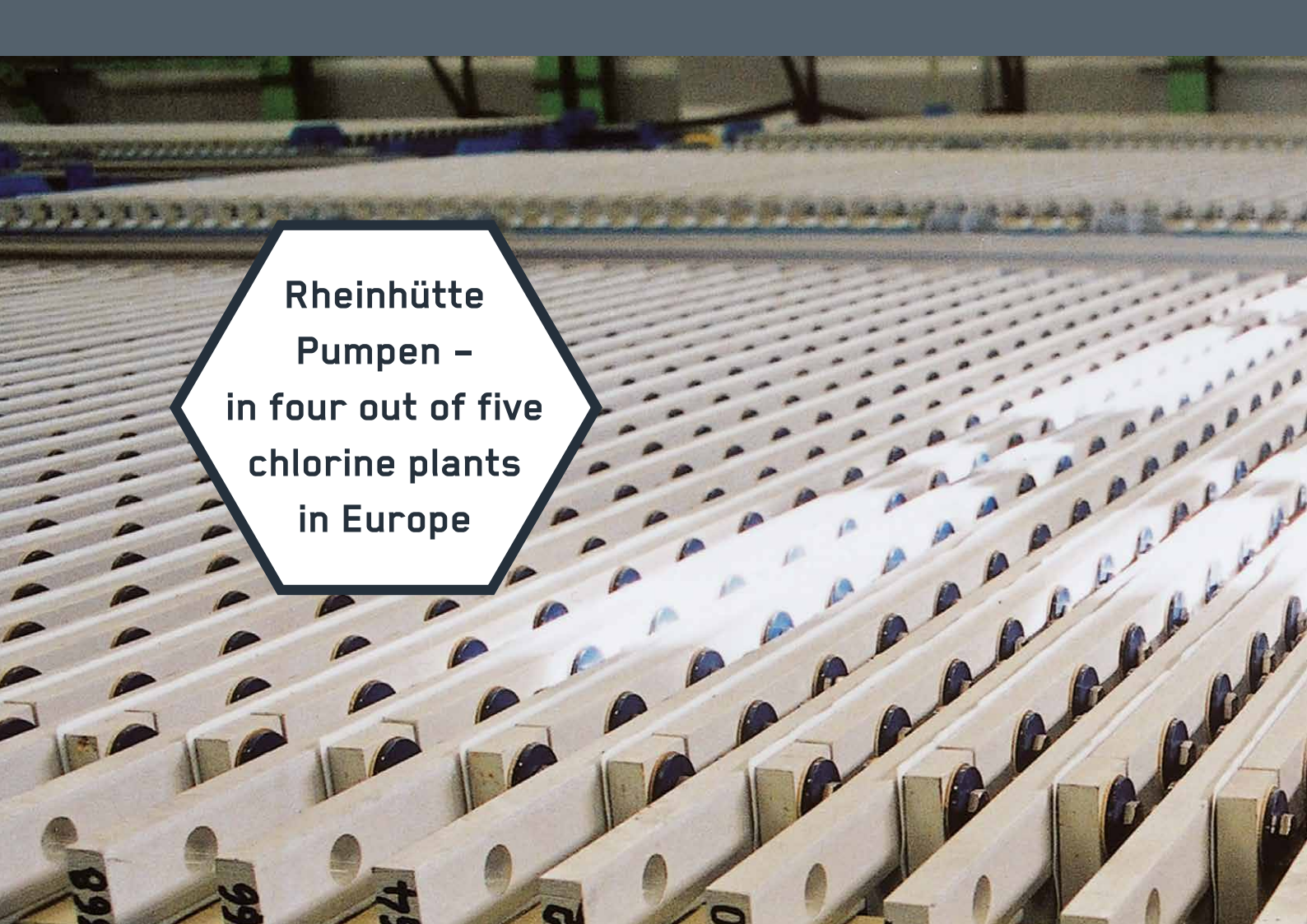

A photograph showing a vast array of white industrial pumps arranged in neat, parallel rows, receding into the distance. The pumps have a consistent design with a circular opening on top and a rectangular base. The background is slightly blurred, showing more of the industrial structure.

**Rheinhütte
Pumpen –
in four out of five
chlorine plants
in Europe**

Special Pumps for the Chlorine Industry

Flexibility, reliability, long lifetimes, simple maintenance and low operating costs are the requirements placed on modern chlorine production plants. RHEINHÜTTE Pumpen continuously develops the family of pumps for the chlorine sector and today offers plant constructors and operators one of the most extensive range of pumps to meet these exacting standards.

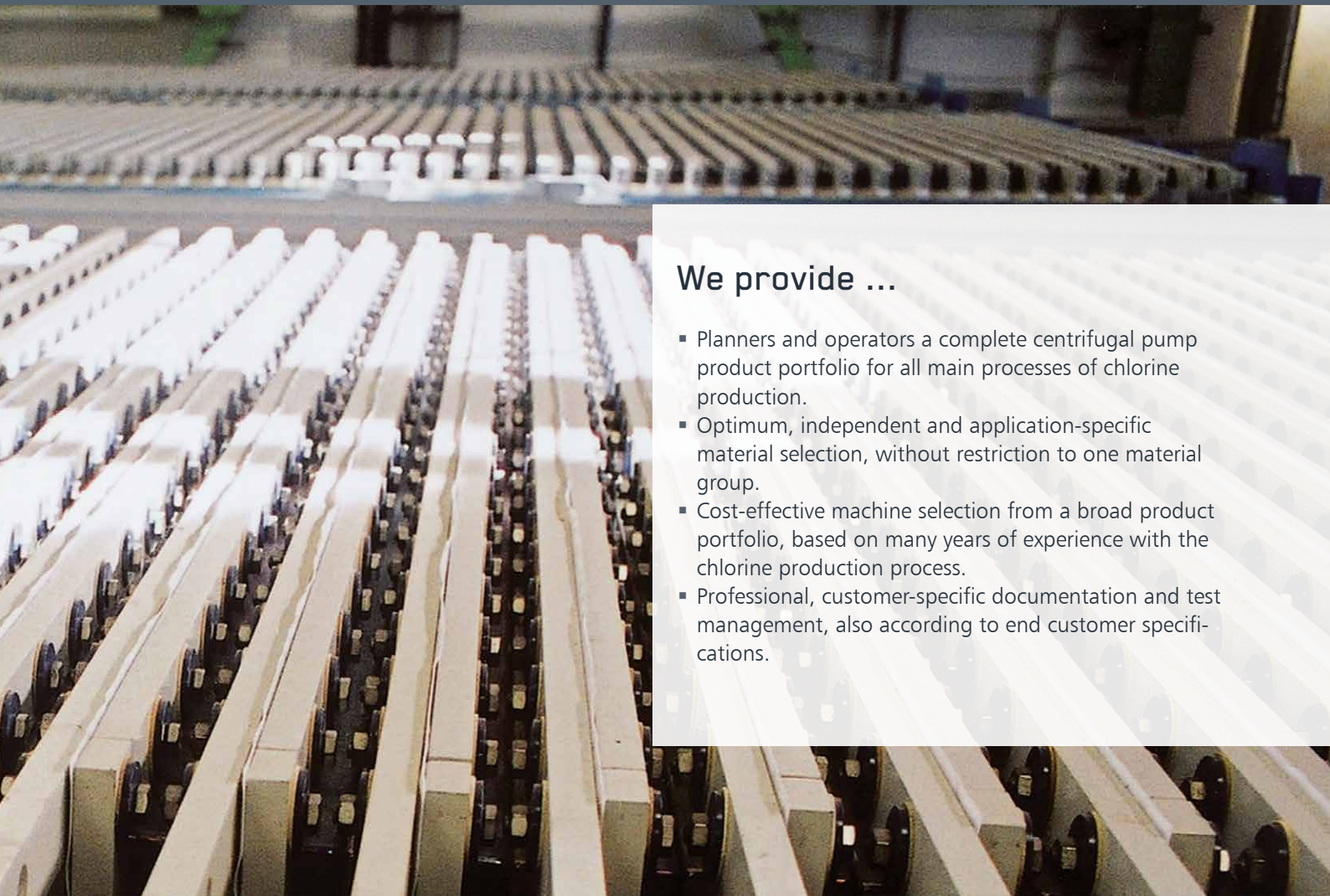

We provide ...

- Planners and operators a complete centrifugal pump product portfolio for all main processes of chlorine production.
- Optimum, independent and application-specific material selection, without restriction to one material group.
- Cost-effective machine selection from a broad product portfolio, based on many years of experience with the chlorine production process.
- Professional, customer-specific documentation and test management, also according to end customer specifications.

Picture: View across the frames of an Uhde membrane cell (Picture source: Copyright by Uhde GmbH)

For many decades now, RHEINHÜTTE Pumpen have been used successfully in all known processes for the production of chlorine. Efficiency, economy and safety are – in view of the aggressive nature and toxicity of the pumped media – always of particular significance.

As the world's only supplier of pumps in all material classes, RHEINHÜTTE Pumpen has a wealth of experience

in the chlorine industry. Whereas previously use was made almost exclusively of pure metal pumps made from titanium, titanium-palladium and nickel in the catholyte and anolyte circuit, pumps made from plastic (e.g. PTFE, PVDF and PE 1000) are now also increasingly becoming an established fixture in the industry.

Product Range

A Wide Variety of Designs for Chlorine Industry

The product family of RHEINHÜTTE Pumpen offers specific solutions for all industrial processes of chlorine production. Diversity and flexibility characterise RHEINHÜTTE Pumpen, especially in the pump design. Taking into account the special requirements of the pumped

media and the individual customer wishes, the appropriate Rheinhütte pump is designed, the right material is selected and the optimum sealing system is chosen. In this way we have been a successful partner in chlorine production for decades.



	RN	FNPM	RCNKu	RCNKu+	RMKN
Assembly type	Horizontal	Horizontal	Horizontal	Horizontal	Horizontal
Q _{max}	2.700 m ³ /h 11,890 us. gpm	350 m ³ /h 1540 us. gpm	2.500 m ³ /h 11,007 us. gpm	400 m ³ /h 1,760 us. gpm	500 m ³ /h 2,200 us. gpm
H _{max}	150 m 490 ft	100 m 328 ft	60 m 197 ft	110 m 361 ft	150 m 490 ft
Medium temperature max.	+300 °C +572 °F	+190 °C +374 °F	+190 °C +374 °F	+130 °C +266 °F	+250 °C + 482 °F
Submersible depth max.	–	–	–	–	–
Solid content max. %	~ 5 %	–	~ 5 % / 30 %*	~ 5 %	~ 2 %
Impeller design	closed, open	closed	closed	closed, vortex impeller	closed, open
Shaft seal type	hydrodynamic shaft seals with and without stuffing box packing, mechanical seal	magnetic coupling	mechanical seal	mechanical seal	magnetic coupling
Materials	cast steel, various stainless steels, nickel-based alloys, titanium, nickel, TiPd	Fluoropolymers	Polypropylene, polyethylene, Polyvinylidene fluoride, Polytetrafluorethylene	Polyolefins and fluoropolymers	wear-resistant alloys, cast steel, various stainless steels, nickel-based alloys



FGP	FGP Unit	RNSi	GVSO	RKuV
Horizontal	<p style="writing-mode: vertical-rl; transform: rotate(180deg);">Tailor made design. For details see brochure of the vacuum pump FGP.</p>	Horizontal	Vertical	Vertical
700 m ³ /h 3,082 us. gpm		1.500 m ³ /h 6,604 us. gpm	4.000 m ³ /h 17,610 us. gpm	120 m ³ /h 528 us. gpm
-		100 m 328 ft	180 m 591 ft	60 m 197 ft
+120 °C + 248 °F		+300 °C +572 °F	+600 °C +1112 °F	+100 °C +212 °F
-		-	17,5 m 57 ft	+1,8 m 5,9 ft
-		~ 5 %	~ 2 %	~ 5 % / 30 %*
open		closed	closed	open
mechanical seal		mechanical seal, hydrodynamic shaft seals	mechanical seal, stuffing box packing, magnetic coupling (GVSOM)	Labyrinth seal, lip ring seal
Ceramics		SIGUSS	Cast steel, various stainless steels	Polypropylene, polyethylene, polyvinylidene fluoride

RHEINHÜTTE Pumpen – Everything from One Source

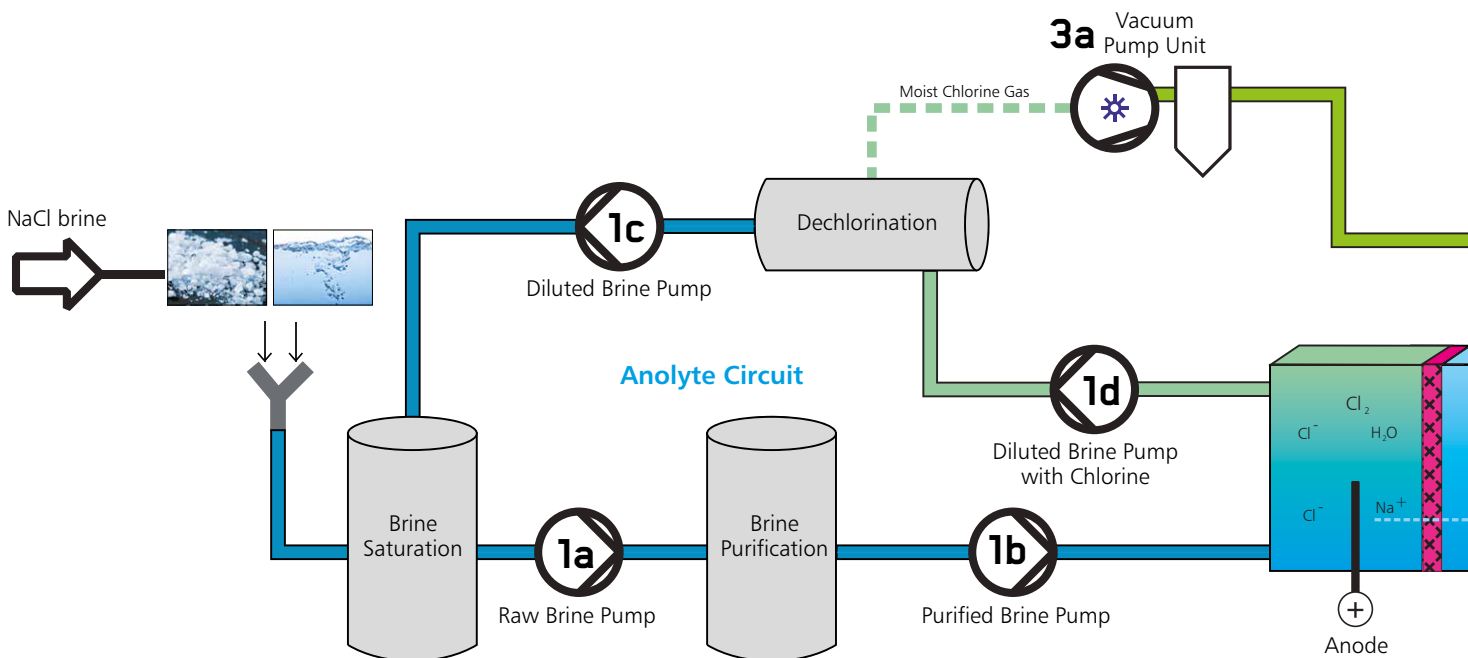

The Rheinhütte family of pumps offers specific solutions for all industrial processes of chlorine production. In membrane electrolysis plants for salt brines or hydrochloric acids, our pumps have been successfully represented worldwide in all stages of the process for many decades now.

When it comes to pumping catholytic solutions (NaOH , 80°C) – to protect the electrolysis membranes from Fe-ions – only pure, iron-free pump materials can be considered for use. Rheinhütte Pumpen successfully makes use here of centrifugal pumps made from nickel, ETFE, PFA or PTFE.

On the anolyte side (see diagram: 1a, 1b, 1c, 1d), identical RHEINHÜTTE pumps made from titanium, titanium palladium or PTFE complement our range.

The pumping of moist chlorine gas (3a) presents supreme demands for the corrosion resistance of all of the

components which are used. Solid ceramic liquid ring vacuum pumps have proved their worth for many decades here and they offer a unique alternative to special pumps made from titanium. Sulphuric acid is used to dry the moist chlorine gas. At this point even titanium is not suitable as a material for pumps. Only the special material SIGUSS which has been developed by Rheinhütte guarantees – along with PTFE and PFA – long lifetimes for centrifugal pumps.

With due consideration of the special requirements for the pumped media and the express wishes of individual customers, the »appropriate« Rheinhütte pump is designed, the right material is chosen and the optimum type of seal is selected.

This approach has ensured that for more than 60 years we have been a successful partner in the chlorine industry – worldwide.

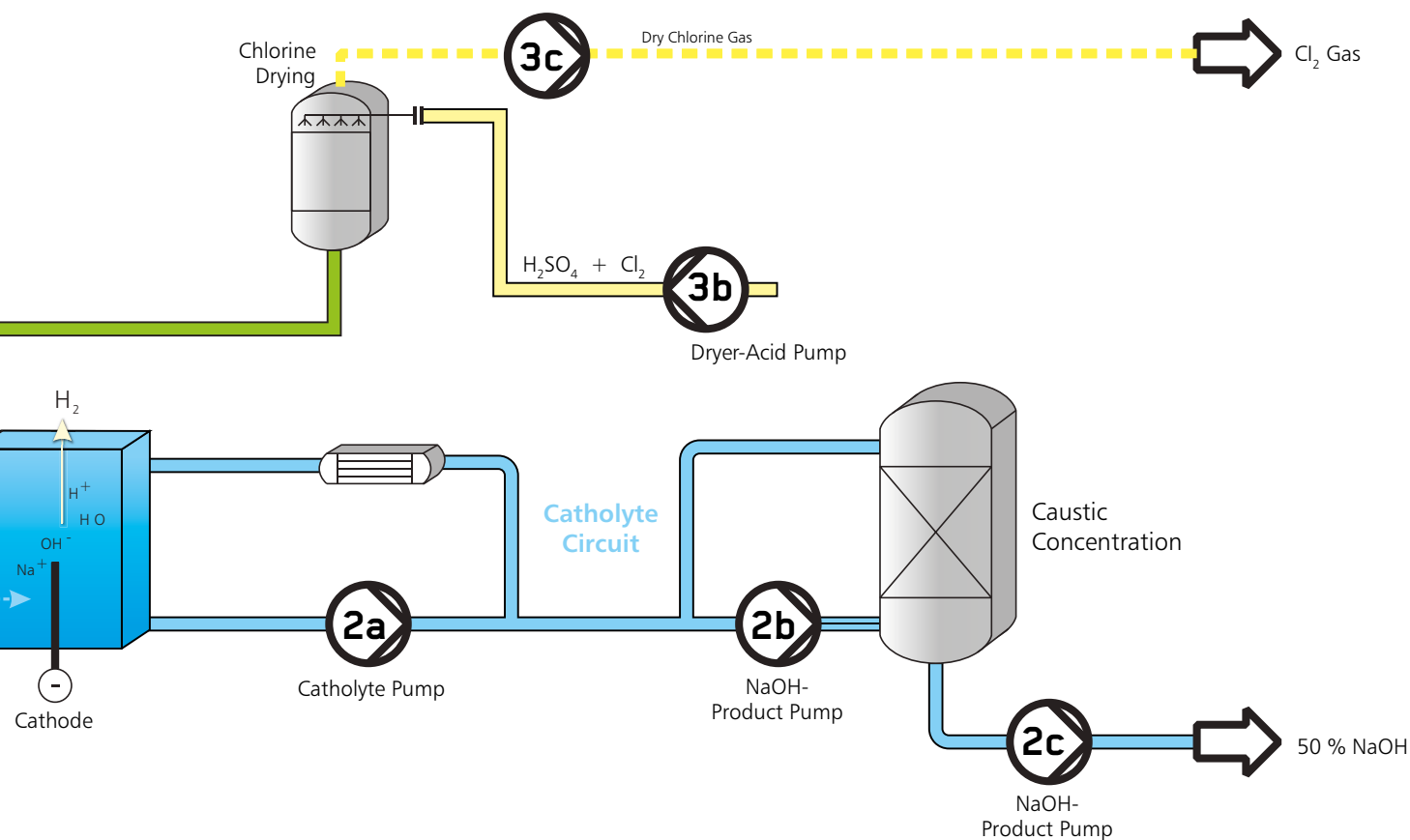

Position	Medium	Pump type	Material
1a, 1b, 1c	310 g/l NaCl – Brine – Chlorine free – Raw brine / Purified brine / Diluted brine	RN, RMKN	Super duplex, Super austenite, Titanium, TiPd
		RCNku, FNPM	PTFE, PFA, PVDF, PE1000
1d	Chlorine containing brine 200g/l NaCl	RN, RMKN	Titan, TiPd
		RCNku, FNPM	PTFE, PFA, PVDF
2a	Catholyte – 31% NaOH Caustic soda	RN, RMKN	Nickel
		RCNku, FNPM	PTFE, PFA, ETFE
2b	Hot Catholyte – 31% NaOH Caustic soda	RN, RMKN	Nickel, Super austenite (R3020)
		RCNku, FNPM	PTFE, PFA, ETFE
2c	Cold caustic soda NaOH	RN, RMKN	Super austenite (R3020), 1.4517
		RCNku, FNPM	PTFE, PFA, ETFE, PE1000, PP
3a	Moist chlorine gas	FGP	Frikorund
3b	Chlorine containing sulphuric acid	RNSi	Siguss
		FNPM, RCNku	PTFE, PFA
3c	Dry chlorine gas	GVSO(M)	Austenite (1.4408), Ceramics
	Liquefied chlorine gas	GVSO	Austenite (1.4408)

Material Selection

Metal Materials

1.4517

Duplex (Semi-austenitic), molybdenum and copper alloyed material with a high resistance to pitting and stress corrosion. This material is one of the super duplex steels. Depending on the pH-value suitable for chloride containing Anolyte brine, raw brine and pure brine.

R 3020

Fully austenitic special stainless steel with a high of chrome and nickel content. High resistance to pitting, stress corrosion and intercrystalline corrosion. Suitable for 70 % caustic soda up to 200 °C, sulphuric acid at all concentrations at low and medium temperatures, sulphuric acid pickling solutions, in certain areas of the manufacture of phosphoric acid, for pumping solutions with a high chloride content and in spin baths.

1.4529 S

A fully austenitic cast material highly resistant to acidic media containing solids and rich in chlorides. Used in absorber and quench fluids of the FGD, acidic and chloride containing gypsum slurries, phosphoric acid production, in vaporization and crystallization processes and for hot sea water.

3.7031 (Titanium)

Titanium is especially resistant to heavily oxidising and chloride containing media. The material is preferred for use in chloralkali-electrolysis, bleaching solutions containing chlorine and in the manufacture of acetic acid.

3.7032 (Titanium Palladium)

Titanium alloyed with palladium. This improves the corrosion resistance in reducing media, e.g. in solutions of iron chloride or aluminium chloride containing hydrochloric acid.

2.4170

Nickel is mainly used for alkali evaporation, pumping molten alkalis and other highly refined alkalis that are not contaminated with iron ions.

2.4686

Highly resistant nickel-base alloys for special applications such as liquids containing high chloride, hydrochloric acid, FGD liquids, heavily contaminated phosphoric acid, hypochlorites and solutions with oxidizing chlorides.

SIGUSS

Highly corrosion resistant chromium alloy silicon cast iron with a good resistance to wear and increased chemical resistance. This material is chemically resistant to H_2SO_4 at all concentrations up to boiling point, therefore for all sulphuric acid applications including the evaporation of waste sulphuric acid, Siguss is virtually indispensable.



Plastic Materials

PP – Polypropylen

In many applications PP represents an economical alternative to high grade metallic materials. It can be used for working temperatures between 0 °C and 100 °C. PP is a proven plastic for secondary processes.

PE 1000 (UHMW-PE) – Polyethylen

Ultra high molecular low pressure polyethylene is used exclusively. Suitable for temperature ranges between -50 °C and 80 °C. Its general resistance to corrosion sometimes exceeds that of PP. Due to its very high resistance to wear, centrifugal pumps made of PE are often used for media which have corrosive and abrasive properties.

PVDF – Polyvinylidenfluorid

The partial fluorination of this polymer increases its chemical resistance many times over. PVDF is resistant to most solvents, acids and oxidizing agents. For many applications in the chemical industry PVDF is an optimal material for temperatures from -20 to 130 °C.

PFA – Perfluoralkoxi

PFA is a perfluorinated alkyl vinyl ether ether. Centrifugal pumps lined with PFA can be used up to 180 °C. With a few exceptions this material has a universal resistance to chemicals.

PTFE – Polytetrafluorethylen

PTFE shows an outstanding resistance against nearly all organic and inorganic media over a wide temperature range. Centrifugal pumps made of PTFE can be used between -50 °C and 180 °C.

Ceramic Materials

FRIKORUND

A silicate ceramic material with very high wear resistance due to its high corundum content. It can be used up to 120 °C. With the exception of strong, concentrated or hot alkalis, hydrofluoric acid and liquids containing fluoride, FRIKORUND can be used in all aqueous media. This material proved suitable e.g. in solid-containing pickling liquor with elevated temperature.

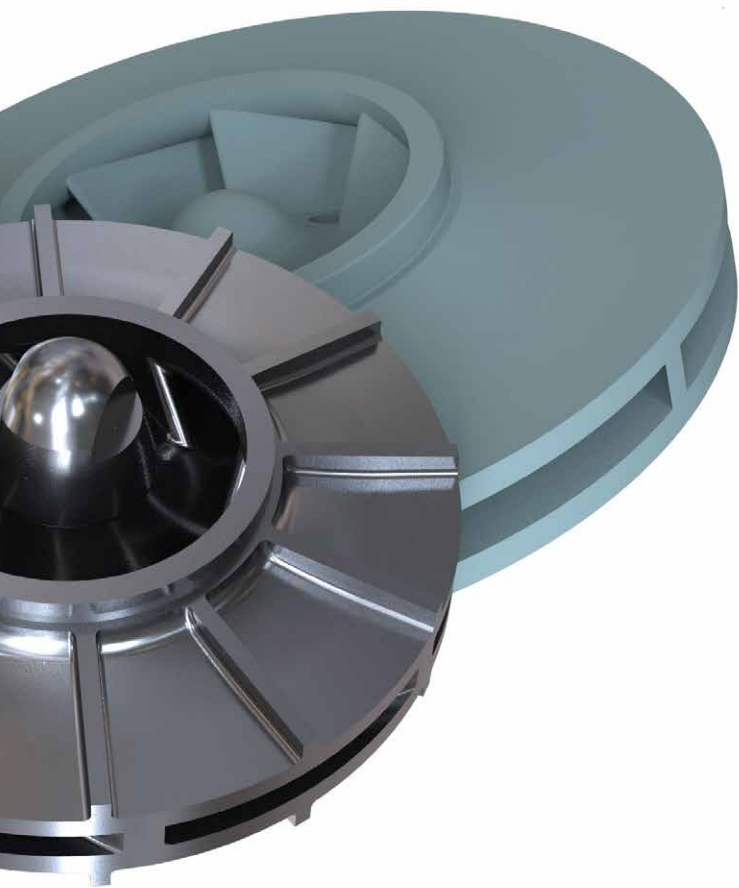

Safety Sealing Variants

Mechanical seals

Single or double acting mechanical seals are used to seal the shaft gland. Sealing is achieved through axial sliding faces which are pressed against each other by spring force and this prevents them opening when at rest. The stationary part of the mechanical seal usually sits in a housing and the rotating unit on the shaft sleeve. In the sealing gap between the sliding faces a lubricating film is generated by the pumped medium in order to prevent the sliding faces running dry.

Allpac S

The standard mechanical seal Allpac S can be used universally, even with abrasive media, and is also characterised by its ease of maintenance due to the small number of components. In the double seal design, a standard mechanical seal is used on the atmosphere side, which can be designed according to customer specifications. The sealing pressure supply is carried out according to the standard API plans.

RHETA® - Easy To Assemble

The metal-free mechanical seal designed by RHEINHÜTTE Pumpen is characterised by its high level of serviceability. Disassembly and assembly can be carried out quickly and smoothly from one side, which is a great advantage for maintenance and servicing. Due to the intelligent parts concept, it is also possible to change, quickly and easily, from a single to a double-acting mechanical seal. The parts for the second mechanical seal are simply retrofitted. RHETA® consists of innovative, metal-free materials, which contribute to the long service life of the seal due to their corrosion resistance. The individual parts of the seal are made of chemically stable plastics and have a high degree of standardisation. Chambers and channels are designed to optimise the flow for the respective barrier and flushing concepts.

Single-acting mechanical seal RHETA® CS with service flushing

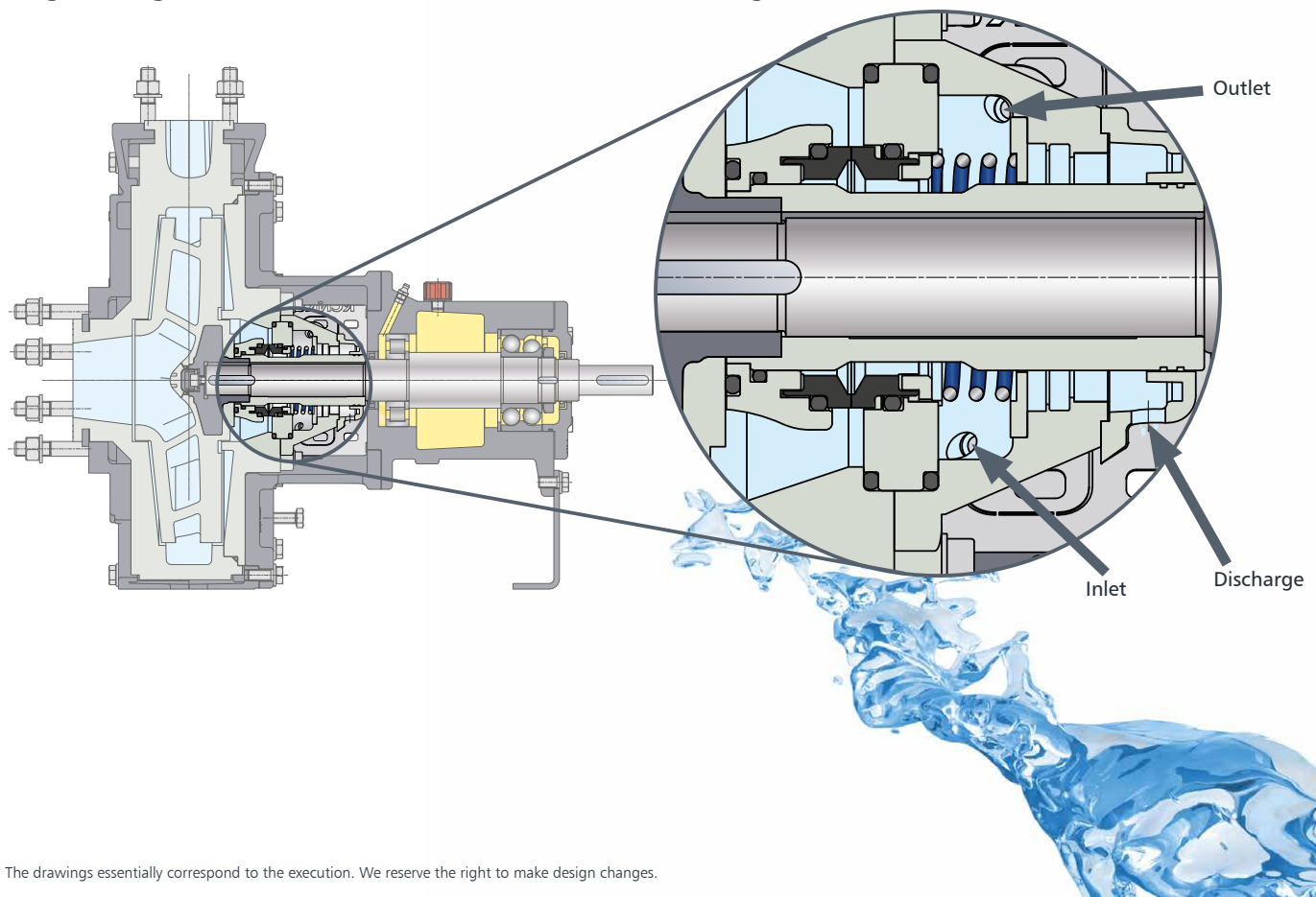

The drawings essentially correspond to the execution. We reserve the right to make design changes.

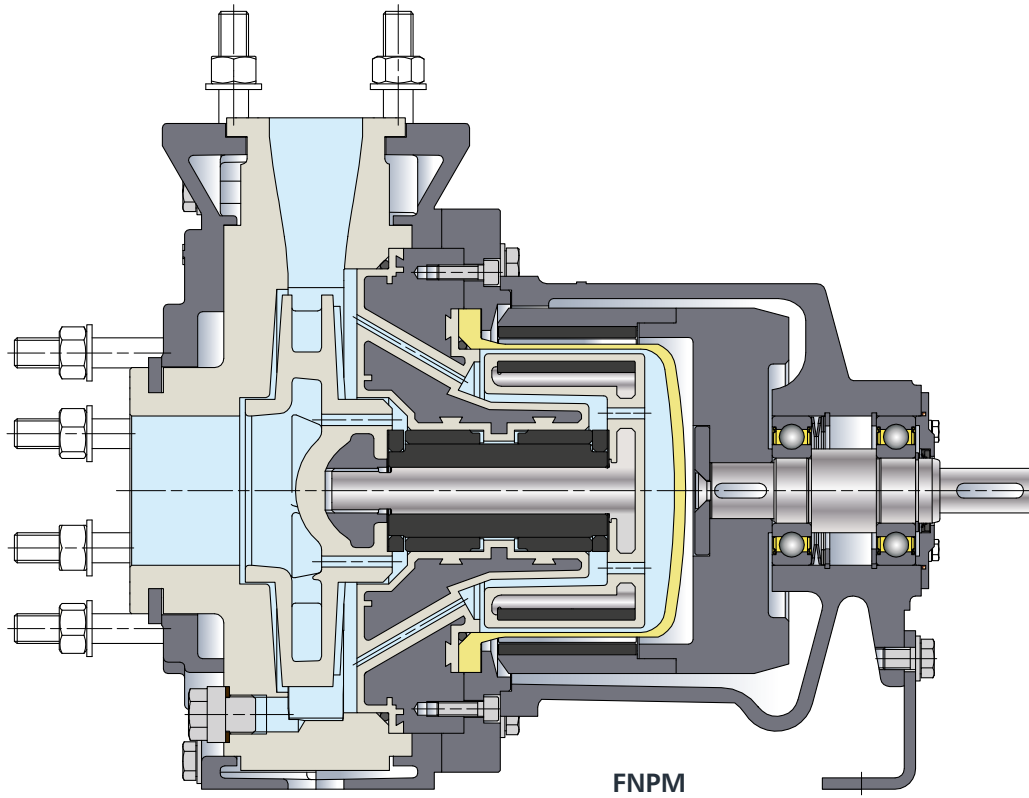

Magnetic coupling

Magnetically coupled standard chemical pumps are particularly suitable for use in media that are largely free of solids. Due to the complete separation of the wetted hydraulics from the atmosphere by a containment can, this design is 100% leak-free. The torque is transmitted by high performance magnets on the inner and outer rotors.

Rheinhütte is the only manufacturer to use ceramic zirconium oxide cans as standard for the magnetic drive pump FNPM made of plastic. The hard surface of the cans effectively reduces the risk of leakage through starting rotors in the event of an accident. Modern zirconium oxide containment cans are insensitive to vibrations and tension.

Metal magnetic drive pumps of the RMKN type are also preferred for cold and hot caustic soda lye or solid-free brine.

Advantages:

- Emission-free and particularly safe due to ceramic can
- Maintenance-free and not susceptible to faults
- Long service life due to optimized material selection



— An ITT Brand

ITT RHEINHÜTTE Pumpen GmbH
Rheingastrasse 96-98
D-65203 Wiesbaden
T +49 611 604-0
info@rheinhuette.com
www.rheinhuette.de