

# RCNKu<sup>+</sup>

## Horizontal Plastic Pump

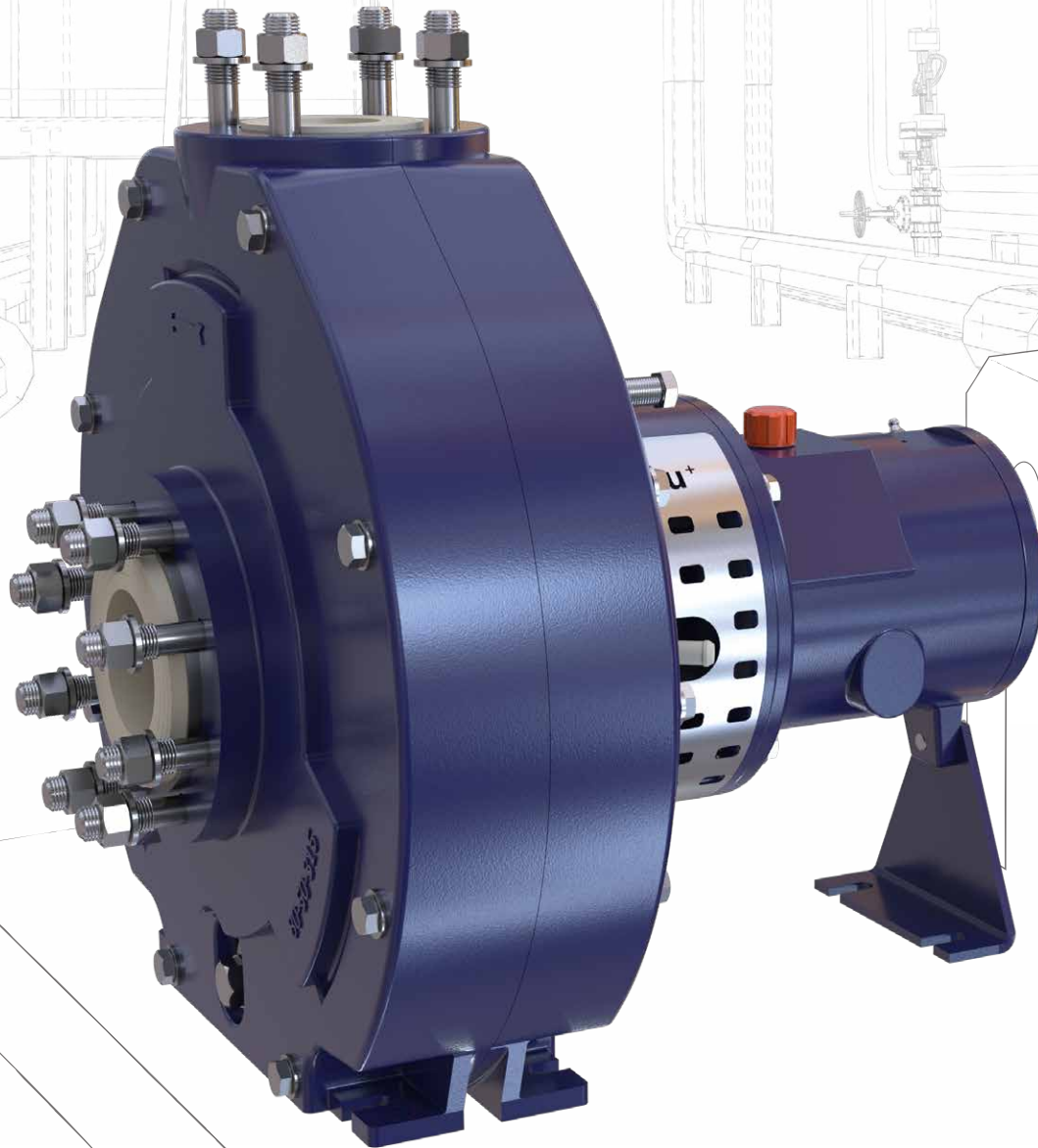



# RCNKu<sup>+</sup>

## Cost-Effective, Easy to Service and Durable

The RCNKu<sup>+</sup> combines the many years of experience in the construction of plastic pumps with a high level of innovation. Our plastic pumps stand for safety, reliability and flexibility, this series is no exception.

The optimum choice of materials forms the basis of the long life cycle. Examples are the solid plastic parts, the robust bearing and the metal-free mechanical seal.

The RCNKu<sup>+</sup> also offers some economic advantages:

The new developed hydraulics provide an operating cost benefit by high efficiencies and low power consumption.

We focus on a high level of operational reliability through intelligent design details. Due to the high standardization of components an efficient and therefore economical spare parts stocking is possible.

### Design features

- Standard: EN 22858 (ISO 2858), ISO 5199
- Design: horizontal, single-stage
- Construction: back-pull-out design
- Casing design: single volute casing
- Impeller: closed
- Bearing lubrication: grease or oil lubrication
- Installation versions: base plate, base frame or stilt mounting
- Ambient temperature: -20 °C to 60 °C (-4°F to 140 °F)
- Solid content limit value: ca. 5 %

### Options

- Drain of volute casing
- Flushing in different versions
- Temperature and vibration monitoring
- Flange processing in line with international standards
- Thermosyphon system
- Storage and priming tank
- Pump accessories



## Fields of application

- Brine
- Chemical Wastewater
- Chloralkali
- Flue gas scrubbers  
(waste incineration plants)
- Hydrochloric acid
- Scrubber
- Sea water
- Steel industry
- Sulphuric acid

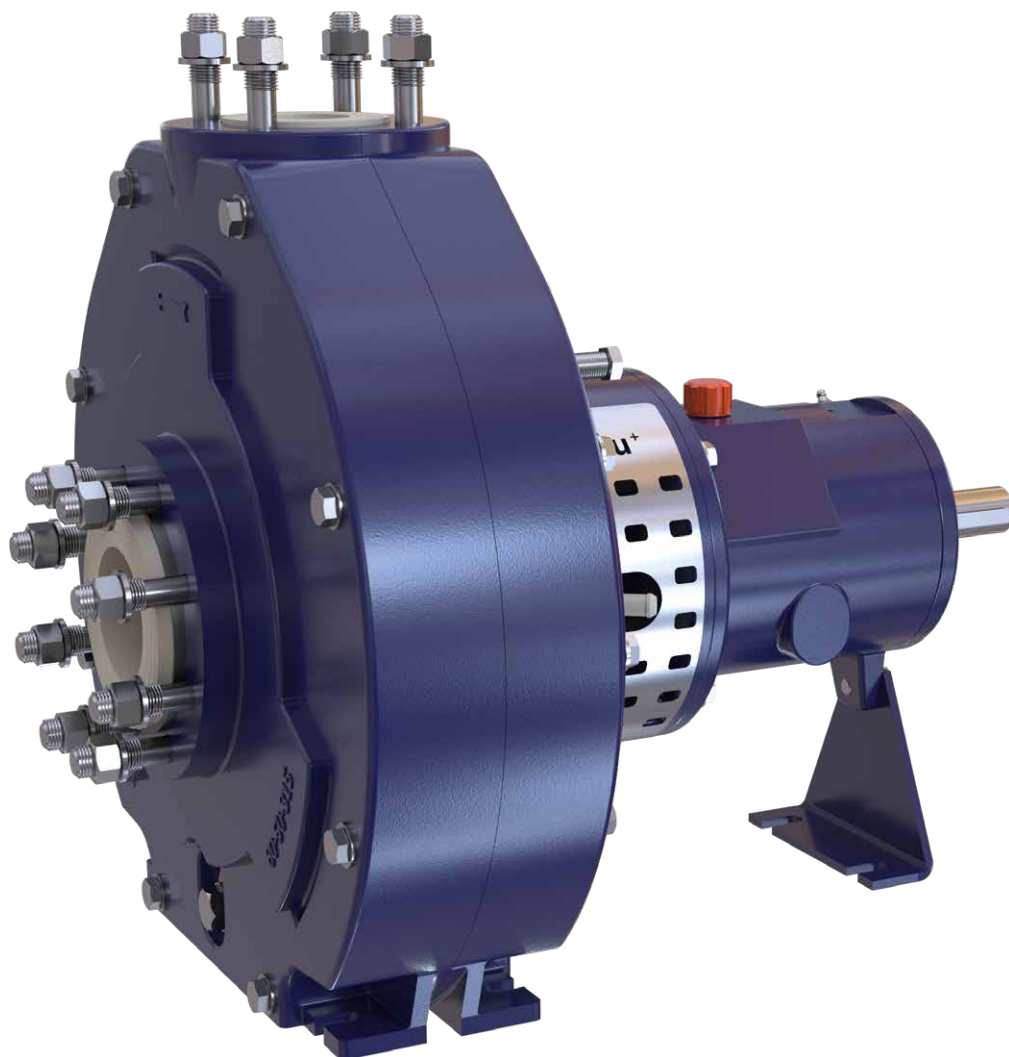

# Main Features

**1** The basis for the development of this robust volute casing is a CFD simulation of the hydraulics. The performance and efficiency can thus be optimally assessed. The solid plastic parts of the housing are resistant to wear and thus durable.

**2** All wheels are available in the plastics PP, PE 1000, PE 1000R or PVDF. Even with increased solids content in the medium, the impeller manages the conveying tasks without difficulty due to the optional back vanes.

**3** The mechanical seal RHETA® is made of innovative materials that ensure a long service life. All parts in contact with media are metal-free and made of durable plastic. Can be used for API Plans 52/53A/54 and 62.

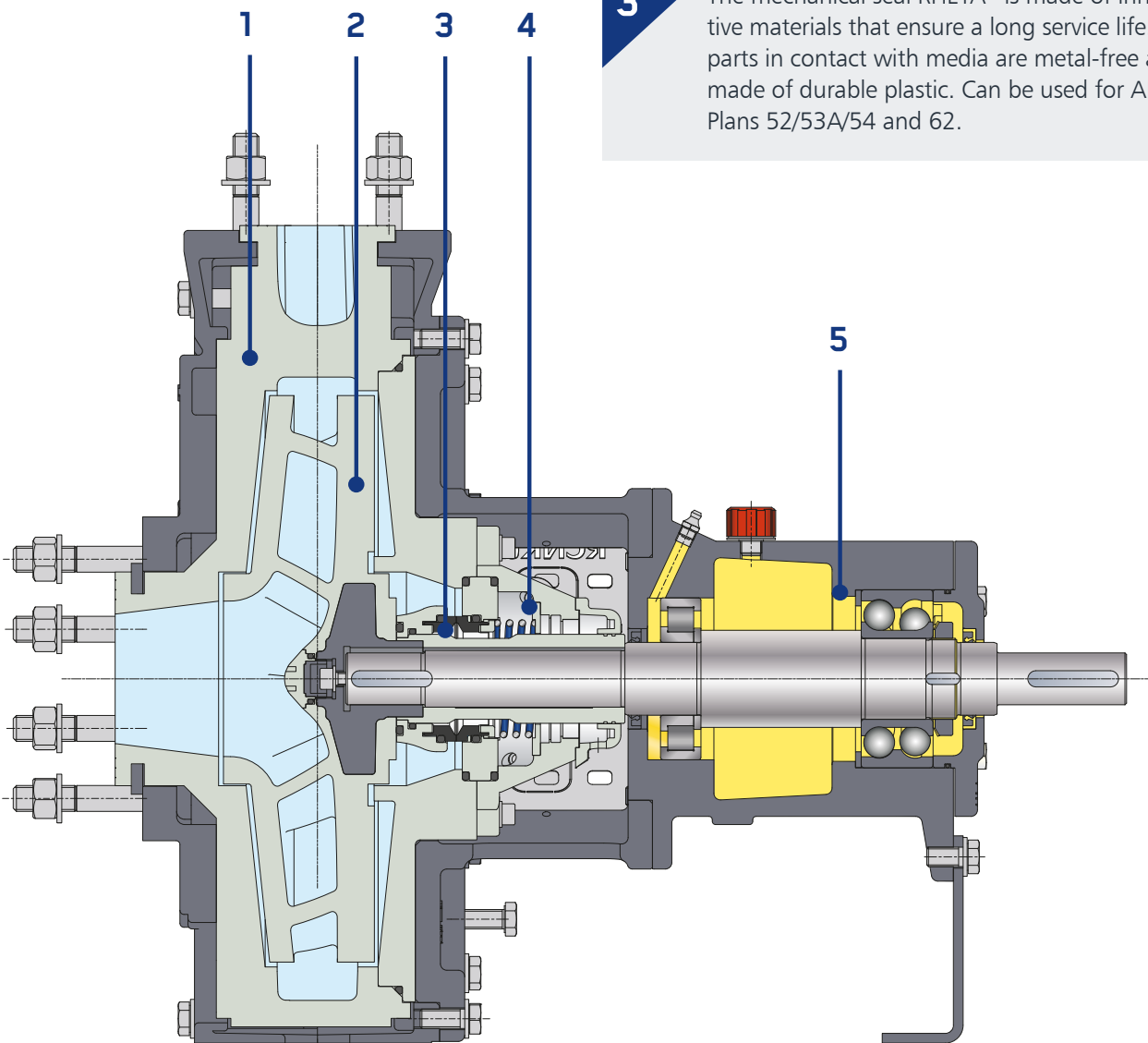

**4** Service flushing is included in the standard CS design. It conveys the liquid upwards and can be executed in the installed condition. See page 7 for detailed information.

**5** Even in the standard version, the robust bearing bracket features continuously lubricated antifriction bearings with high load ratings. A rigid shaft material ensures low vibration even in unfavourable operating conditions.

The drawings essentially correspond to the execution. We reserve the right to make design changes.

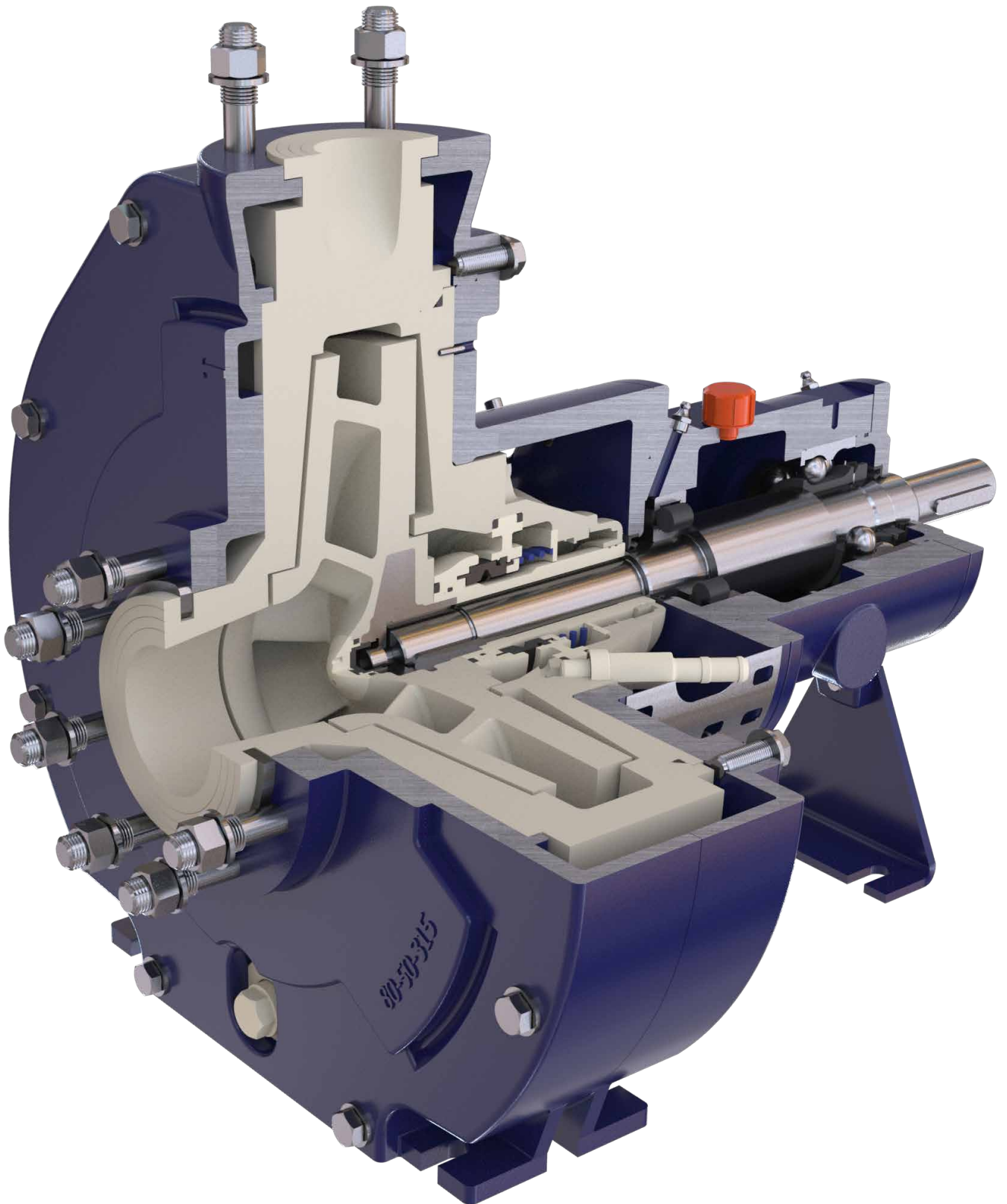

# Mechanical Seal

## RHETA® - Easy To Assemble

Our mechanical seal RHETA® is a highlight of this series. The metal-free mechanical seal is characterised by its high level of serviceability. Disassembly and assembly can be carried out quickly and smoothly from one side, which is a great advantage for maintenance and servicing. Due to the ingenious parts concept, it is also possible to change, quickly and easily, from a single to a double-acting mechanical seal. The parts for the second

mechanical seal are simply retrofitted. RHETA® consists of innovative, metal-free materials, which contribute to the long service life of the seal due to their corrosion resistance. The individual parts of the seal are made of chemically stable plastics and have a high degree of standardisation. Chambers and channels are designed to optimise flow for the respective individual rinsing concepts.

### Single-acting mechanical seal CS with service flushing

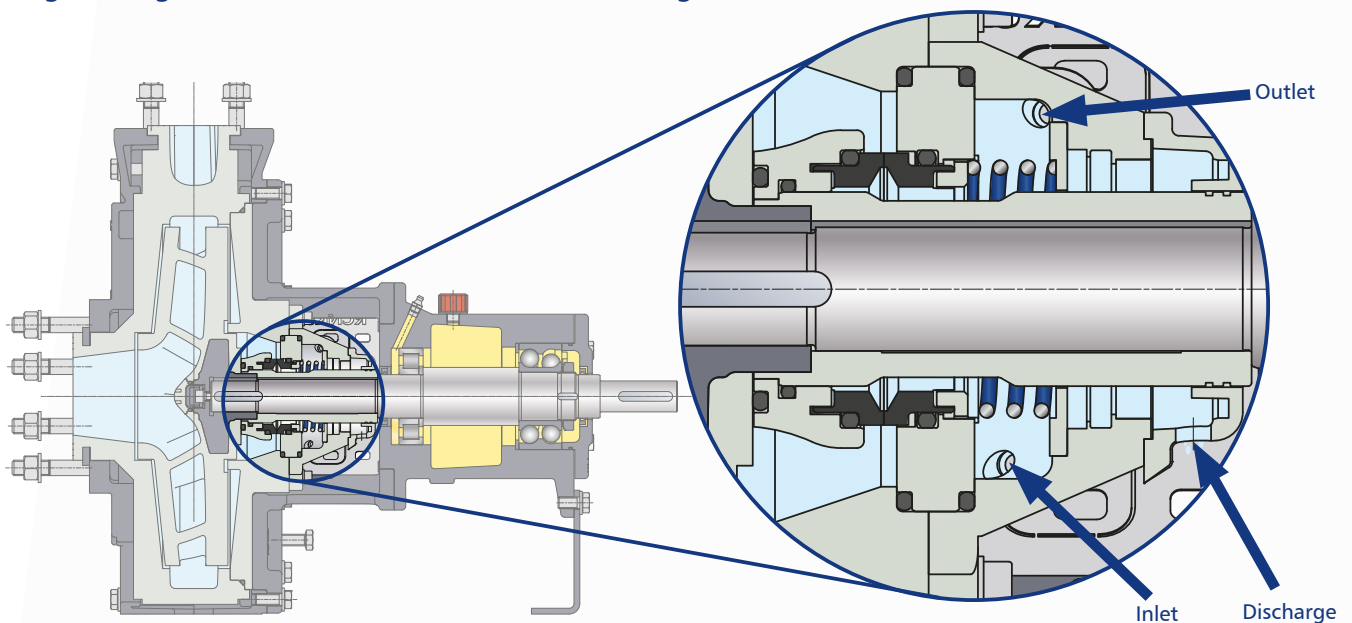

The drawings essentially correspond to the execution. We reserve the right to make design changes.

## Double-acting mechanical seal CST

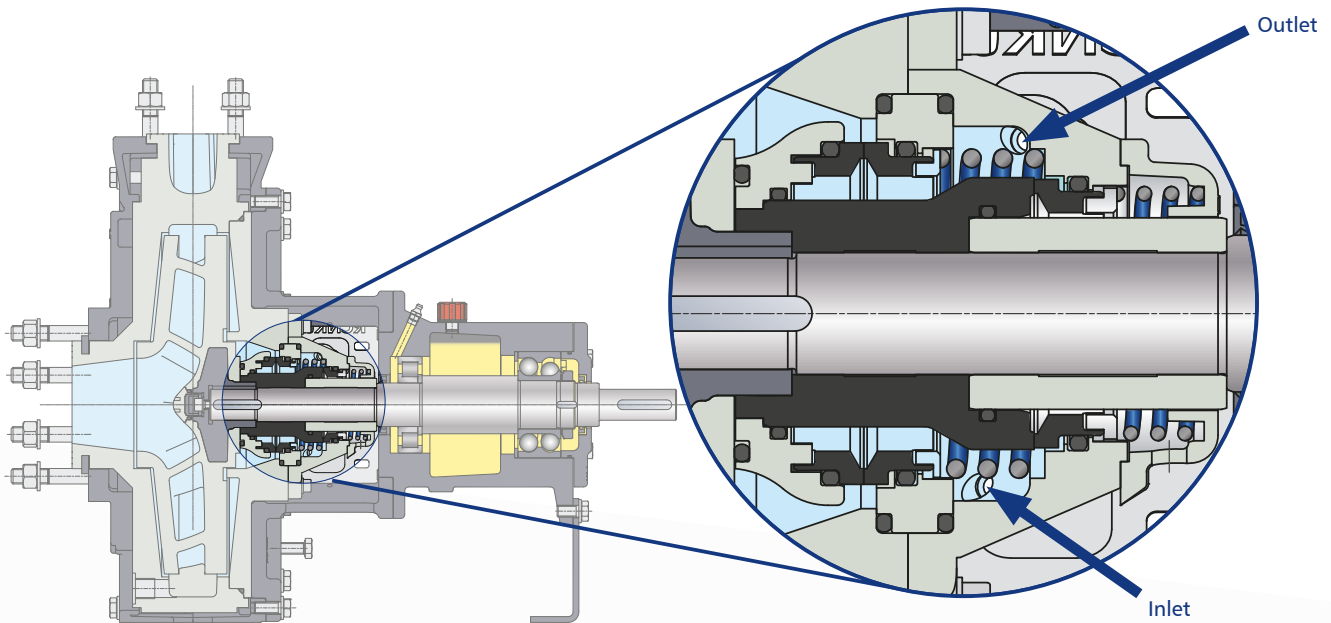

## Service flushing as standard

RHETA® offers a cost-effective solution for regular rinsing, as service rinsing is integrated into the design of the CS product. Crystallisation residues and deposits can be rinsed out of the seal using different rinsing modes. Simple rinsing is possible in the standard CS design, which can be carried out during operation and standstill. So-called service flushing takes place via the lower rinsing connection with a pressure of approximately 0.3 bar. The rinsing liquid is discharged via the upper rinsing connection (see illustration). Rinsing can be performed as often as required.

The CST seal offers a convenient solution when permanent rinsing is needed.

The connection for permanent external flushing (X design) or discontinuous start-up and shut-down flushing (R design) is provided as standard and can be used at any time.

External flushing X / R

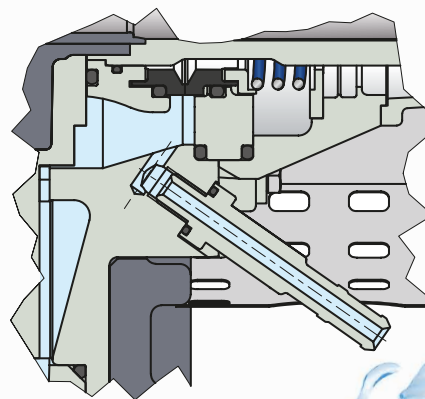

# Variable Plastic Material

The chemical centrifugal pump RCNku<sup>+</sup> is available as standard in four different plastics. Our material experts help you to choose the right material. Plastics are in particular demand in applications with high corrosion resistance requirements, in order to ensure a long pump life cycle.

## PP – Polypropylene

This plastic is particularly suitable for simple, common applications. It offers outstanding performance at temperatures from 0 to 100 °C (32 to 212 °F). PP has proven its worth in acids, alkalis and saline solutions as well as in hydrochloric acid pickling.

## PE 1000 (UHMWPE) – Polyethylene

The outstanding feature of this high molecular weight polymer is its resistance to wear in case of solids in the pumped medium. There is also a wide range of corrosion resistance options. In the temperature range from -50 to +80 °C (-58 to 414 °F), PE 1000 is in many cases an alternative to stainless steels.

## PE 1000R – Polyethylene

PE 1000R is a further development of the standard polyethylene PE 1000 with wear-minimising additives for up to 30% higher durability - for use in highly abrasive suspensions with process-related critical solids content. The material can be used at temperatures from -50 to +80 °C (-58 to 414 °F).

## PVDF – Polyvinylidene fluoride

The partial fluorination of this polymer increases its chemical resistance many times over. PVDF is resistant to most solvents, acids and oxidants. PVDF is an optimum material for many applications in the chemical industry for temperatures from -20 to 130 °C (-4 to 266 °F).



# Pumps & Installation Dimensions

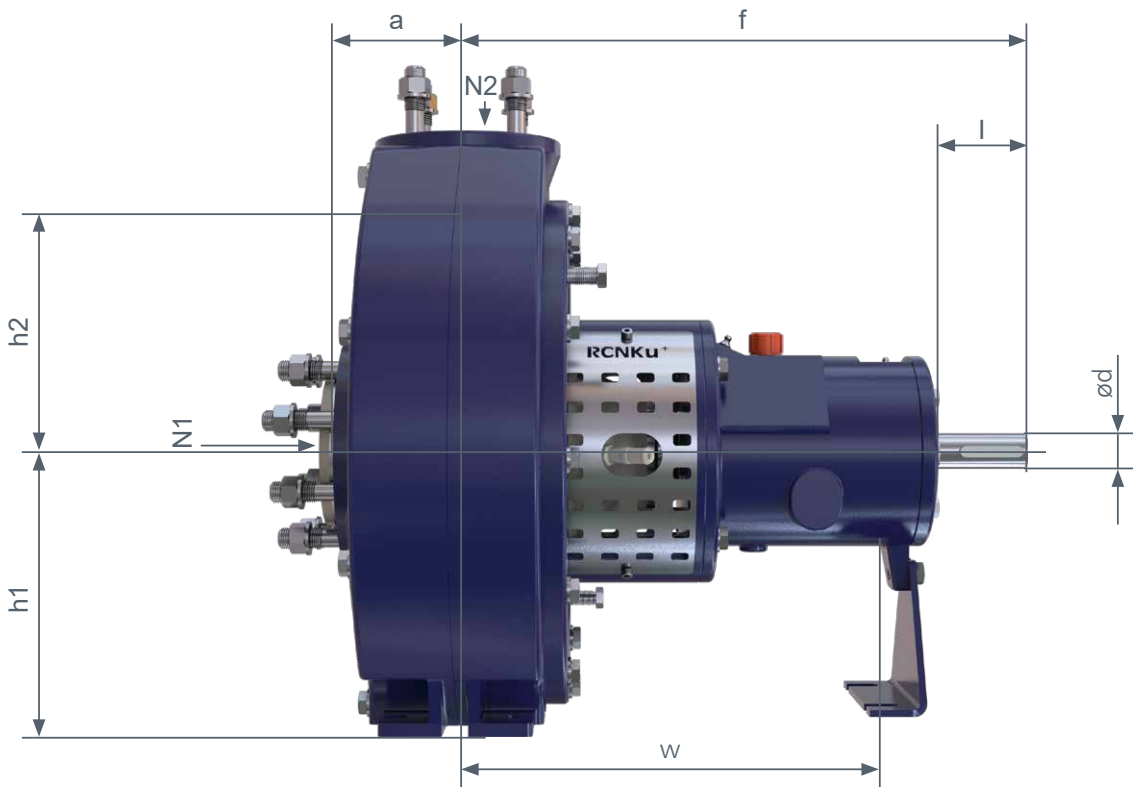

Size	BB	Pump dimensions				Base dimensions	Shaft end		Flange dimensions	
		a	f	h <sub>1</sub>	h <sub>2</sub>		w	ød	l	N1
50-32-160	1	80	385	132	160	285	24	50	32	50
50-32-200	1	80	385	160	180	285	24	50	32	50
65-40-200	1	100	385	160	180	285	24	50	40	65
80-65-160	1	100	385	160	180	285	24	50	65	80
80-50-200	1	100	385	160	200	285	24	50	50	80
65-40-250	2	100	500	180	225	370	32	80	40	65
80-50-315	2	125	500	225	280	370	32	80	50	80
100-80-160	2	100	500	160	200	370	32	80	80	100
100-65-250	2	125	500	200	250	370	32	80	65	100
125-80-200	2	125	500	180	250	370	32	80	80	125
125-80-250	2	125	500	225	280	370	32	80	80	125
125-100-200	2	125	500	200	280	370	32	80	100	125
125-80-315	3	125	530	250	315	370	42	110	80	125
125-80-400	3	125	530	280	355	370	42	110	80	125
125-100-250	3	140	530	225	280	370	42	110	100	125
150-125-315	3	140	530	280	355	370	42	110	125	150
150-125-400	3	140	530	315	400	370	42	110	125	150
200-150-250	3	140	530	280	375	370	42	110	150	200

BB = Bearing bracket N1 = Suction flange N2 = Pressure flange

All dimensions are shown in millimeters.

# Capacity Ranges

RCNKu<sup>+</sup> : 50 Hz n = 1450 /min

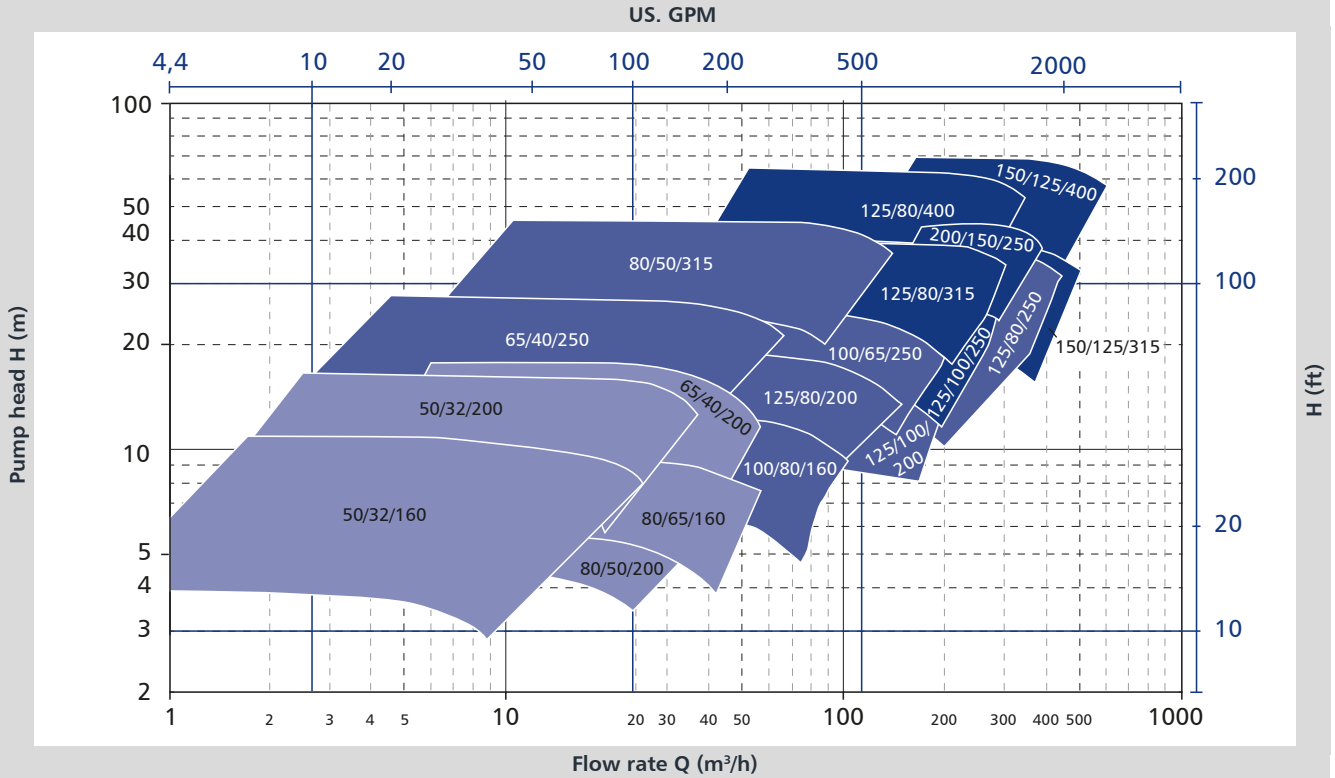

RCNKu<sup>+</sup> : 50 Hz n = 2900 /min

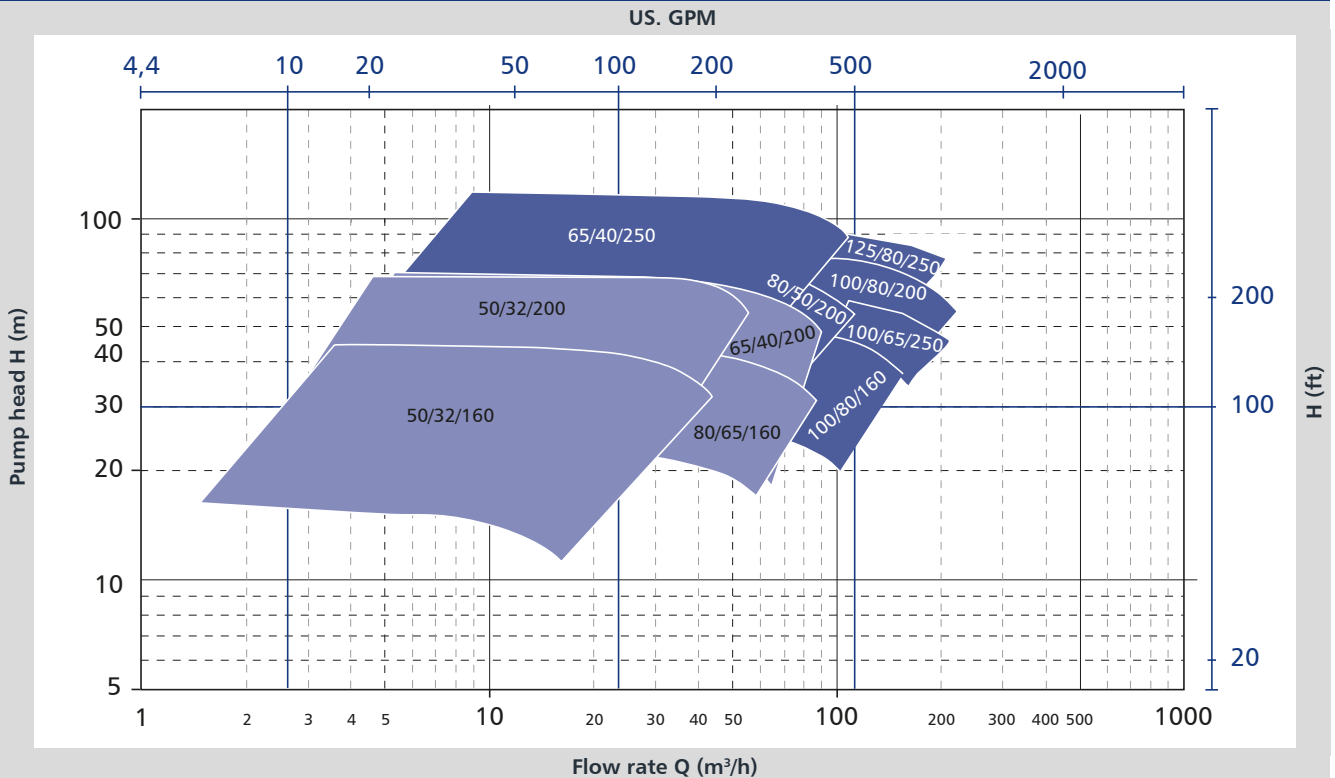

Bearing bracket **1** **2** **3**

RCNKu+ : 60 Hz n = 1750 /min

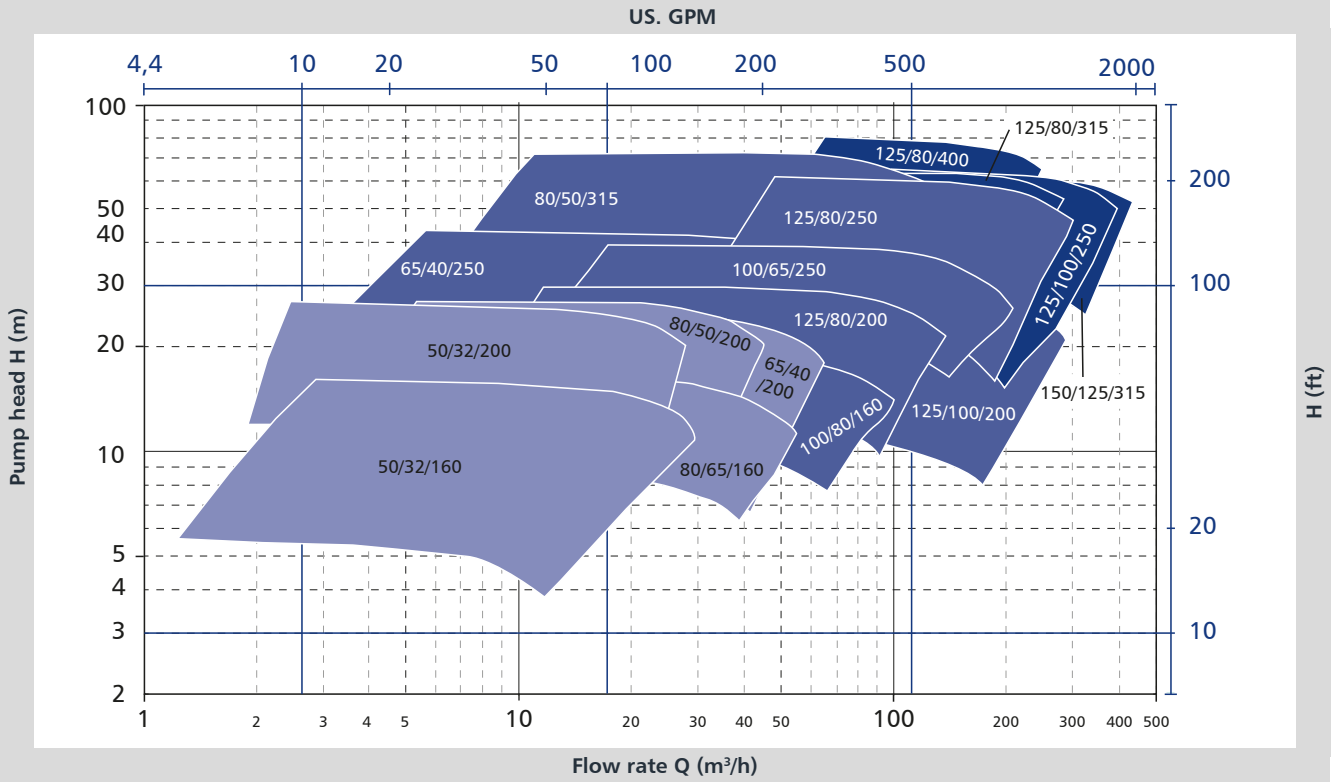

RCNKu+ : 60 Hz n = 3500 /min

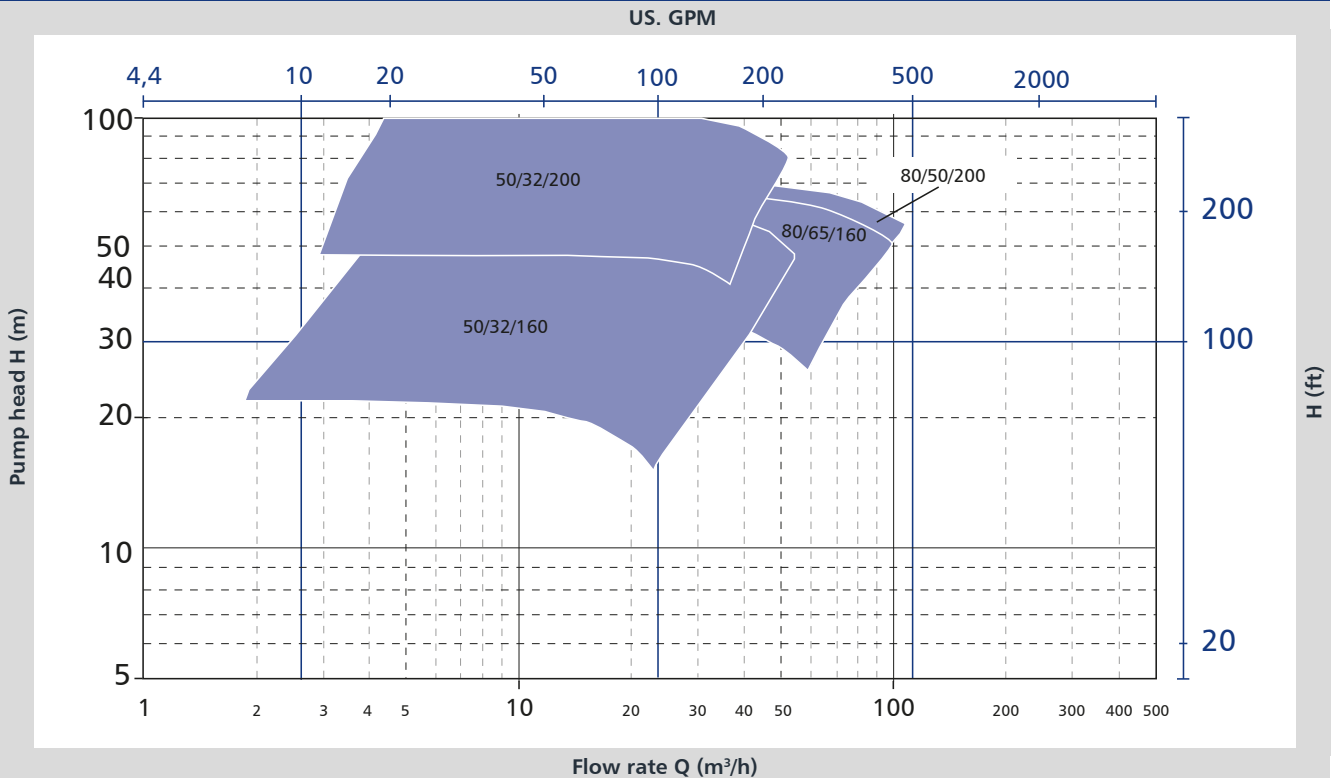



— An ITT Company

ITT RHEINHÜTTE Pumpen GmbH  
Rheingastrasse 96-98  
D-65203 Wiesbaden  
T +49 611 604-0  
info@rheinhuette.com  
www.rheinhuette.de